

# CineLight 120Quad®

Constant Output **Tunable** DMX LED PANELS®

*The ideal lighting system for studio and location cinematography, television, digital, film and video*



*The CineLight 120 Quad® with its square form factor is the choice of lighting cinematographers and television lighting designers for the production of broadcast programs, news, sports and commercial spots. It is also used in corporate videos with high production values and the production of TV series, virtual reality, and greenscreen SFX applications.*

*Lightweight, rugged, ergonomic, self-contained, ecological and affordable.*

*With its big surface of pure white light source of soft or long throw lighting, the CineLight 120 Quad® is the best option for use in high rise studio or near-field productions.*

## EVERY STORY STARTS WITH US

L I G H T S . C A M E R A . A C T I O N



[www.fluotec.net](http://www.fluotec.net)  
[info@fluotec.net](mailto:info@fluotec.net)

**FLUOTEC**  
...WE LIGHT!





## Studio Long Throw LED PANELS & Production SoftLight LED PANELS

Square configuration very high CRI/TLCI >97 color rendering indexes. Constant Output Tunable DMX LED PANELS.

Model	CineLight Production 120 Quad® Tunable SoftLIGHT	CineLight Studio 120 Quad® Tunable Long Throw
Code with Yoke	G6LCNT112	G6LCNT113
Code with Stand Mounting Bracket	G6LCNT114	G6LCNT115
Operation	90-240V - 50/60Hz	90-240V - 50/60Hz
Weight lb/kg	24.25/11	25.35/11.5
Electrical draw	1.79 (213W) @120VAC	1.79 (213W) @120VAC
Remote variable CCT	2700K - 6600K and 8 presets	2700K - 6600K and 8 presets
CRI	>97	>97
Remote dimming control	Via DMX 0% - 100%	Via DMX 0% - 100%
Local dimming control	Digital Display 0% - 100%	Digital Display 0% - 100%

### Technical Specifications

- Light and Powerful 5,522 Lumens
- Manual and/or DMX control
- 8 presets memories for color temperature and custom configurations are allowed between 2700-6600K
- Power supply Powercon cable with switch
- A very high efficiency Broadcast & Cinema luminaire with white light LEDs controlled by our exclusive software-hardware drivers
- Constant luminous output for the whole range (2700-6600K) of CCT is achieved with our proprietary designed calibration curves
- Interchangeable or fixed Diffuser Panels
- Reflective Chamber and LED lens intensifiers
- HALODIM® Stepless CCT & Dimming Technology
- The DMX control software automatically assigns 2 channels, the first for dimming and the second for color temperature

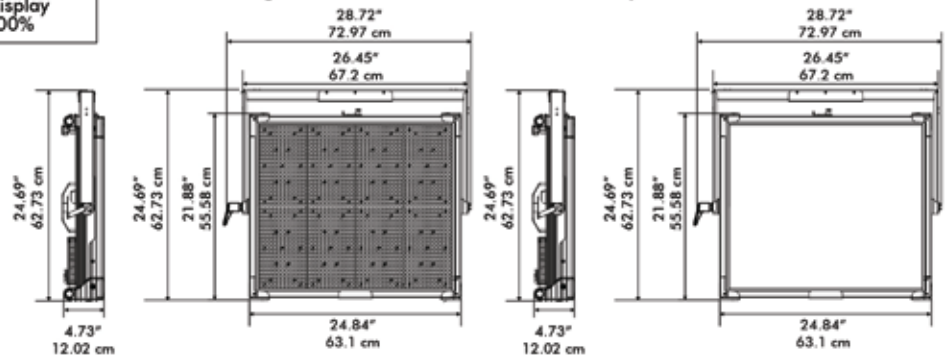

### Photometric Data

1.83m (6.00ft)    2.74m (9.00ft)    3.66m (12.00ft)

Illuminance E Foot-Candles/lux

#### CineLight Production 120 Quad® SoftLIGHT LED PANEL Neutral White



A fixed diffusion softlight panel is installed

#### CineLight Studio 120 Quad® Long Throw LED PANEL Neutral White

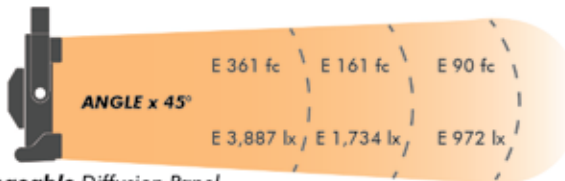

Without Interchangeable Diffusion Panel

#### CineLight Production 120 Quad® Long Throw LED PANEL Neutral White

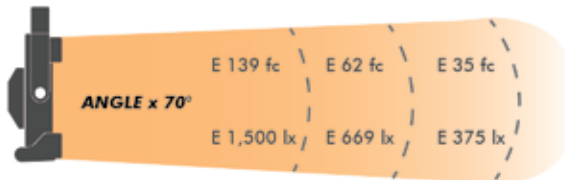

With Interchangeable Diffusion Panel

### CineLight Production 120 Quad® SoftLIGHT LED PANEL

### CineLight Studio 120 Quad® Long Throw LED PANEL



Gel Frame



Gel Frame



16 ft POWERCON AC Cable with Switch G6PLT041



Interchangeable Diffusion Panel G6CNT127



Stand Fitting 5/8" G6FLT057



16 ft POWERCON AC Cable without Switch G6LED134



C-Clamp G6FLT262



Stand Fitting 5/8" G6FLT057



Yoke (Yoke Version)



Safety Cable G6FLT059



Stand Mounting Bracket (Mounting Bracket Version) G6CNT151



Yoke

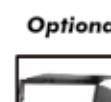

4 Leaf Barndoors Set



C-Clamp G6FLT262

### Optional Accessories: